



For more Hi-Fi manuals and set-up information
please visit www.hifiengine.com

YAMAHA KX-330

Natural Sound Stereo Cassette Deck

Dolby HX Pro Dynamic Bias Servo

Dolby B/C Noise Reduction

Fine Adjustment of Recording Bias with Bias Adjust Control

Play Trim Control for Improved Playback Compatibility with Other Decks

Full/0-M Repeat Play, Music Search and Bi-Directional Intro Scan

Auto Rec Mute/Memory Function

Remote Control Capability

Thank you for purchasing the YAMAHA KX-330 stereo cassette deck.

TABLE OF CONTENTS

Safety Instruction	1
Front Panel Parts and Functions	8
Remote Control Transmitter	10
Features	11
Connections	13
Cassette Tapes	13
Operation	15
Maintenance	17
Specifications	18
Troubleshooting	19

OWNER'S MANUAL



IMPORTANT



Please record the serial number of your unit in the space below.

Model: **KX-330**

Serial No:

The serial number is located on the rear of the unit.

Retain this Owner's Manual in a safe place for future reference.

 <div style="display: inline-block; border: 1px solid black; padding: 2px; text-align: center; margin: 0 10px;"> CAUTION <small>RISK OF ELECTRIC SHOCK DO NOT OPEN</small> </div> 
<p>CAUTION: TO REDUCE THE RISK OF ELECTRIC SHOCK, DO NOT REMOVE COVER (OR BACK) NO USER-SERVICEABLE PARTS INSIDE, REFER SERVICING TO QUALIFIED SERVICE PERSONNEL.</p>

• **Explanation of Graphical Symbols**



The lightning flash with arrowhead symbol, within an equilateral triangle, is intended to alert you to the presence of uninsulated "dangerous voltage" within the product's enclosure that may be of sufficient magnitude to constitute a risk of electric shock to persons.



The exclamation point within an equilateral triangle is intended to alert you to the presence of important operating and maintenance (servicing) instructions in the literature accompanying the appliance.

WARNING

To reduce the risk of fire or electric shock, do not expose this appliance to rain or moisture.

SAFETY INSTRUCTIONS

- 1** Read Instructions — All the safety and operating instructions should be read before the appliance is operated.
- 2** Retain Instructions — The safety and operating instructions should be retained for future reference.
- 3** Heed Warnings — All warnings on the appliance and in the operating instructions should be adhered to.
- 4** Follow Instructions — All operating and other instructions should be followed.
- 5** Water and Moisture — The appliance should not be used near water — for example, near a bathtub, washbowl, kitchen sink, laundry tub, in a wet basement, or near swimming pool, etc.
- 6** Carts and Stands — The appliance should be used only with a cart or stand that is recommended by the manufacturer.
- 6A** An appliance and cart combination should be moved with care. Quick stops, excessive force, and uneven surfaces may cause the appliance and cart combination to overturn.
- 7** Wall or Ceiling Mounting — The appliance should be mounted to a wall or ceiling only as recommended by the manufacturer.



- 8** Ventilation — The appliance should be situated so that its location or position does not interfere with its proper ventilation. For example, the appliance should not be situated on a bed, sofa, rug or similar surfaced that may block the ventilation openings: or placed in a built-in installation, such as a bookcase or cabinet that may impede the flow of air through the ventilation openings.
- 9** Heat — The appliance should be situated away from heat sources such as radiators, stoves, or other appliances that produce heat.
- 10** Power Sources — The appliance should be connected to a power supply only of the type described in the operating instructions or as marked on the appliance.
- 11** Power-Cord Protection — Power-supply cords should be routed so that they are not likely to be walked on or pinched by items placed upon or against them, paying receptacles, and the point where they exit from the appliance.
- 12** Cleaning — The appliance should be cleaned only as recommended by the manufacturer.
- 13** Non use Periods — The power cord of the appliance should be unplugged from the outlet when left unused for a long period of time.
- 14** Object and Liquid Entry — Care should be taken so that objects do not fall into and liquids not spilled into the inside of the appliance.

CAUTION: READ THIS BEFORE OPERATING YOUR UNIT.

15 Damage Requiring Service — The appliance should be serviced by qualified service personnel when:

- A. The power-supply cord or the plug has been damaged; or
- B. Objects have fallen, or liquid has been spilled into the appliance; or
- C. The appliance has been exposed to rain; or
- D. The appliance does not appear to operate normally or exhibits a marked change in performance; or
- E. The appliance has been dropped, or the cabinet damaged.

16 Servicing — The user should not attempt to service the appliance beyond those means described in the operating instructions. All other servicing should be referred to qualified service personnel.

17 Grounding or Polarization — The precautions that should be taken so that the grounding or polarization of an appliance is not defeated.

1. This unit is a sophisticated stereo cassette deck. To ensure proper operation for the best possible performance, please read this manual carefully.

2. Choose the installation location of your unit carefully. Avoid placing it in direct sunlight or close to source of heat. Also avoid locations subject to vibration and excessive dust, heat, cold or moisture. Keep it away from sources of hum such as transformers or motors.

3. Do not open the cabinet as this may result in damage to the deck or electrical shock. If a foreign object should get into the deck, contact your local dealer.

4. When removing the power plug from the wall outlet, always pull directly on the plug; never pull the cord itself.

5. Do not apply excessive force when operating switches and knobs.

6. When moving the deck, be sure to first pull out the power plug and remove all cords connecting the deck to other equipment.

7. Do not attempt to clean this unit with chemical solvents as this may damage the finish. Use a clean, dry cloth.

8. Never allow metallic items (e.g. screwdrivers, tools, etc.) to come near the record/playback head assembly. Doing so may not only scratch or damage the head's mirror-smooth finish, it may also change the magnetic characteristics of the heads, causing a deterioration in reproduction quality.

9. Although the record/playback head used in this unit is a high quality head with outstanding reproduction characteristics, it can become dirty through the use of old tapes or from dust accumulation over time. This can have a serious effect on reproduction quality. Clean the heads regularly with one of the commonly available head cleaners or with cleaning solutions as explained later in this manual.

10. Be sure to read the "Troubleshooting" section of this manual for advice on common operating errors before concluding that your unit is faulty.

11. Keep this manual in a safe place for future reference.

1 FRONT PANEL

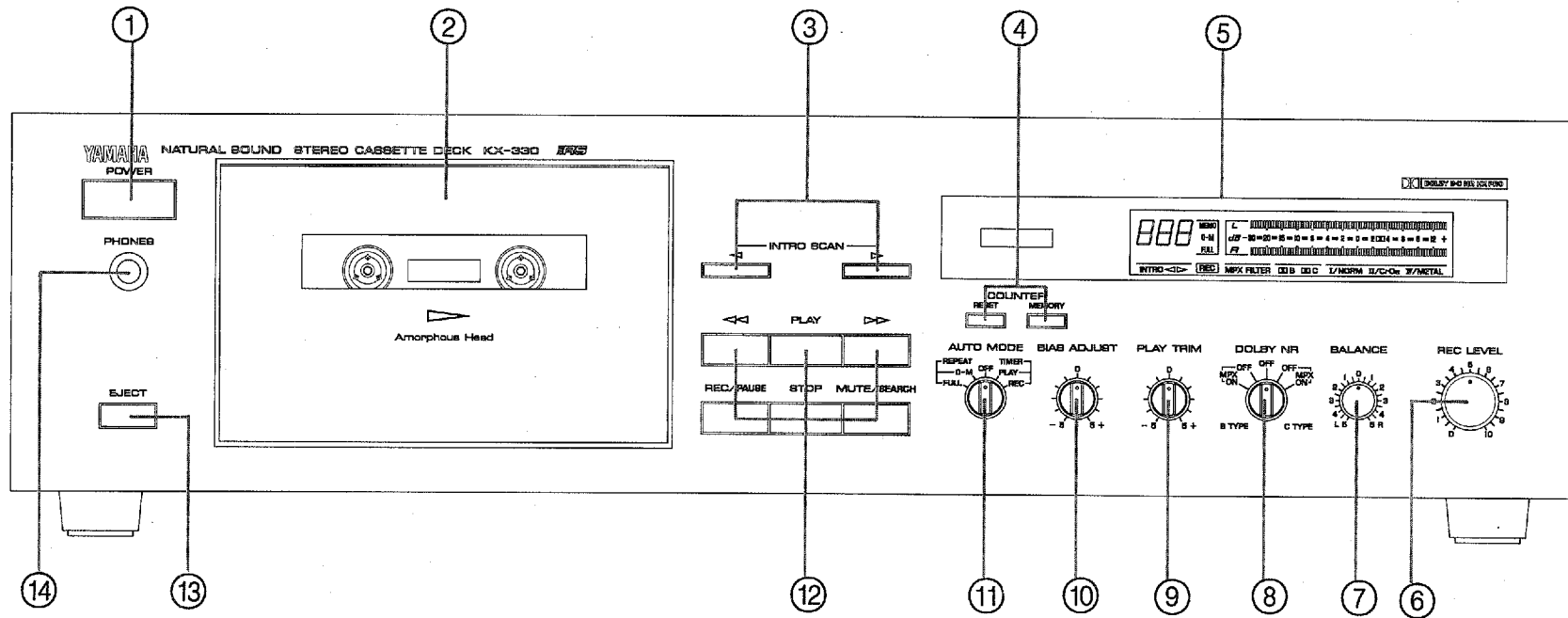

⑤ Display

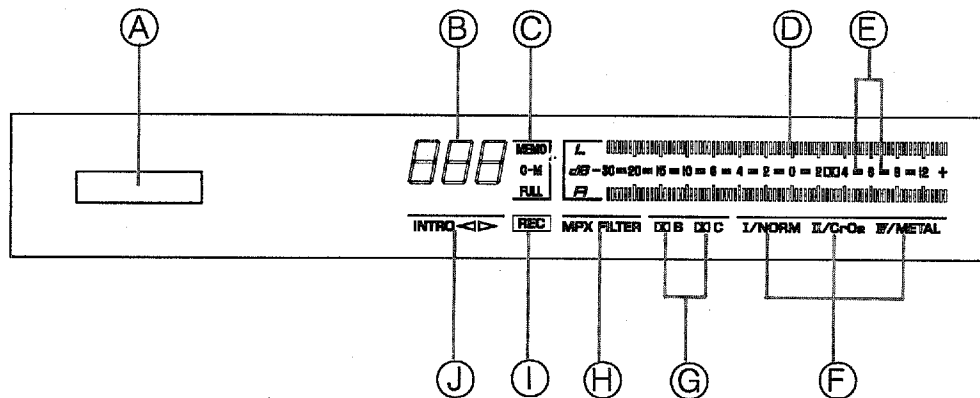

2 REMOTE CONTROL TRANSMITTER

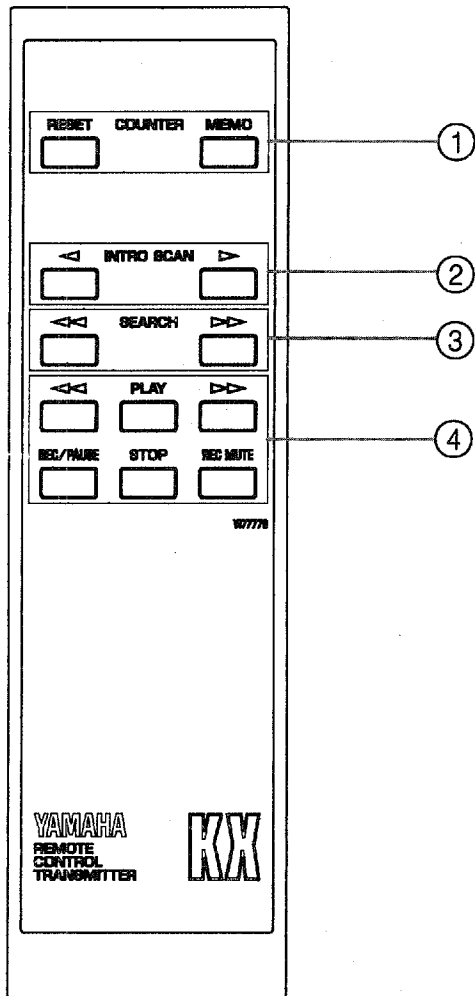

3 BATTERY INSTALLATION

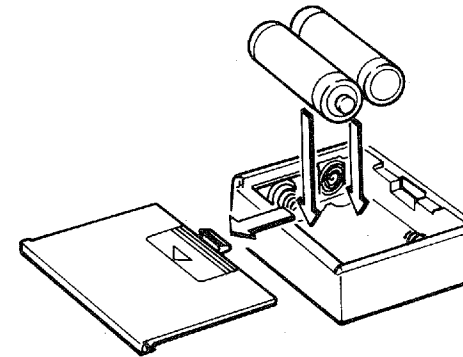

4 REMOTE CONTROL OPERATION RANGE

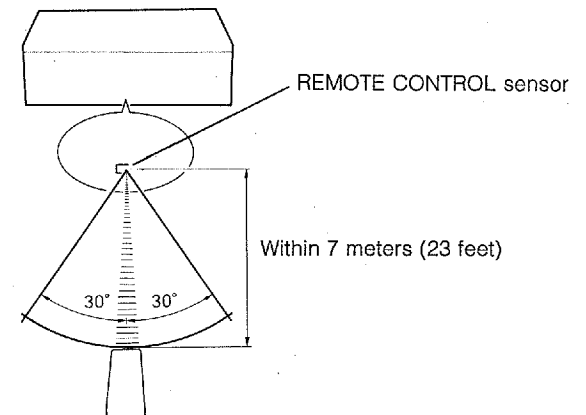

5 REAR PANEL AND CONNECTIONS

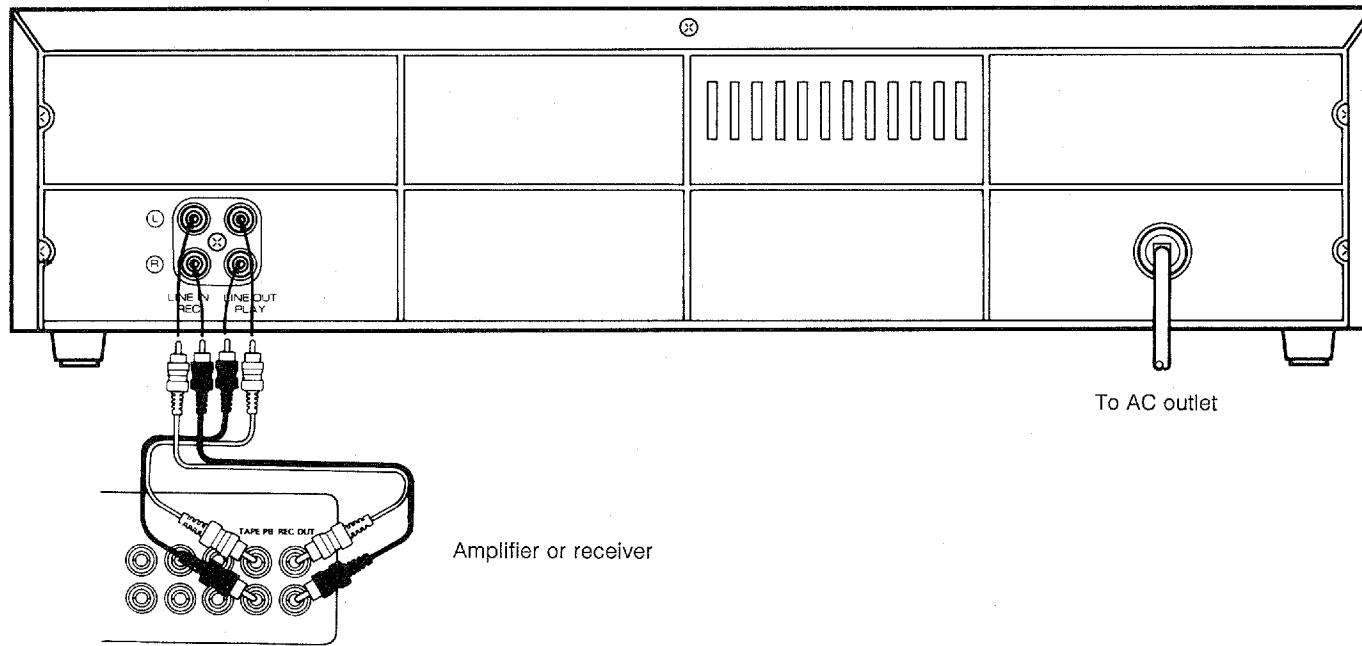

6 DETECTOR SLOTS

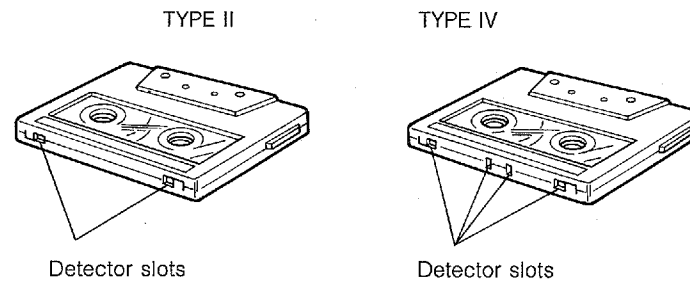

7 RECORDING PROTECTION

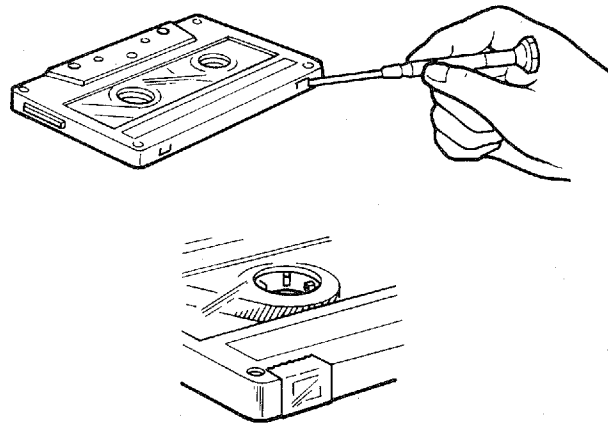

8 TAPE SLACK

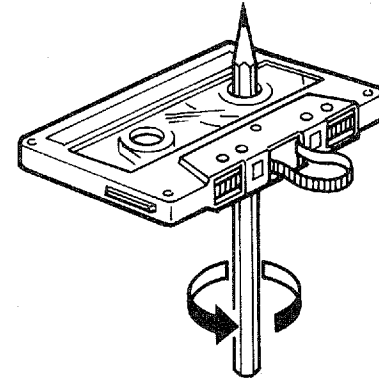

9 TIMER CONNECTION

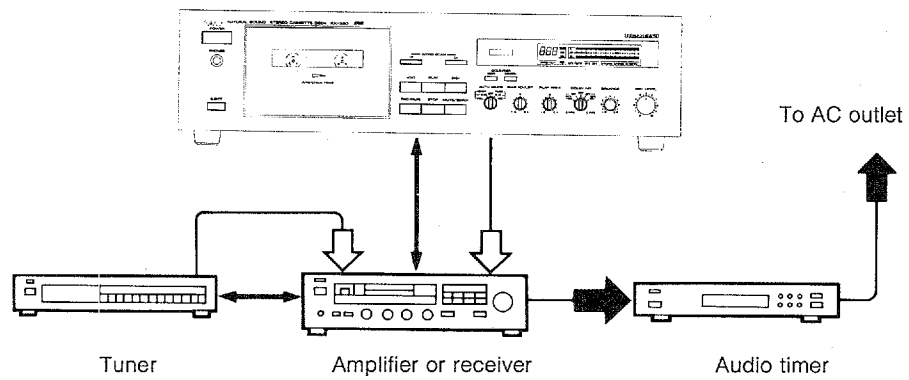

10 CLEANING OF TAPE PATH

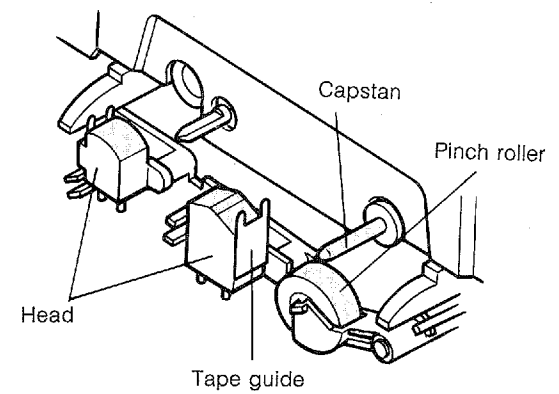

FRONT PANEL PARTS AND FUNCTIONS

(See Fig. 1.)

① POWER switch

Press this switch to turn the power on and off.

② Cassette compartment

To load a cassette tape, press the EJECT button and the cassette compartment will open. Insert a cassette with the exposed tape side facing down and the side to be played facing you. To close the compartment, push in the compartment door until it locks.

③ INTRO SCAN ◀ and ▶ buttons

Press one of these buttons to play back the first 15 seconds approximately of each selection in the desired direction. Once the desired selection is found, press the PLAY button to defeat the Intro Scan mode and engage the Play mode.

④ COUNTER buttons

RESET: Press the RESET button to reset the counter reading to "000". It can also be used to specify a new "000" point and cancel the previous counter readings memorized for 0-M repeat or 0-stop operation.

MEMORY: Pressing the MEMORY button memorizes the desired counter reading. This function is used for 0-M repeat operation.

During fast forwarding or rewinding, the tape will stop at the counter reading point where the MEMORY button was pressed (Memory Stop).

To cancel the memorized counter reading, press the MEMORY button again.

- Set the AUTO MODE selector to the OFF position for Memory Stop operation.

⑤ Display

Ⓐ REMOTE CONTROL sensor

This sensor receives signals from the remote control transmitter.

Ⓑ Counter

Use this counter as an aid in locating points on a tape.

Ⓒ Repeat/Memory function indicators

MEMO: Lights when a count number has been memorized by pressing the MEMORY button. Pressing the MEMORY button again turns the indicator off and erases the memory.

0-M : Lights when the 0-M repeat function is activated: when the AUTO MODE selector is set to 0-M REPEAT.

FULL : Lights when the FULL repeat function is activated: when the AUTO MODE selector is set to FULL REPEAT.

Ⓓ PEAK level meters

Indicate the peaks of the signal levels during recording and playback over a -30 dB to +12 dB range. There are separate meters for each LEFT and RIGHT channel. These meters have a peak hold function. This function holds the peak level for 1 or 2 seconds.

Ⓔ Optimum recording level indicators

The optimum recording level indicators appear as lighted segments between the numbers of the signal level scale. The highest level position of the indicators automatically changes according to the type of tape loaded.

Ⓕ NORM, II/CrO₂, IV/METAL tape type indicators

When a tape is loaded, the built in Auto Tape Selector's sensors will automatically determine what type of tape is loaded, adjust for proper bias, level and equalization for that type of tape, and light the corresponding indicator.

- Automatic tape selection does not function for the early model Metal type tapes which do not have the necessary detector slots.
- The deck is not designed for use with Ferrichrome (III/FeCr) tapes.

Ⓖ □□ B and □□ C noise reduction indicators

The indicators will light to indicate the activation of the corresponding Dolby noise reduction.

Ⓗ MPX FILTER indicator

This indicator lights when the MPX FILTER is activated.

① **REC indicator**

Lights during the Record and Rec/Pause modes. It will blink on and off during Mute operation.

② **INTRO ◀▶ indicator**

This indicator lights when the Intro Scan function is activated. It also indicates the direction of the Intro Scan operation.

⑥ **REC LEVEL control**

This control is used to adjust and set the recording level. Turning it clockwise increases the recording level, and turning it counterclockwise decreases the recording level.

⑦ **BALANCE control**

This control is used to balance the recording levels of the left and right channels. Turning it clockwise decreases the left channel's recording level, while turning the control counterclockwise decreases the right channel's recording level. Normally, adjust this control so that left and right recording level indicators peak to the same reading.

⑧ **DOLBY NR selector**

OFF: Set to this position if no noise reduction is desired.

In the OFF position, signals do not pass through the noise reduction circuits and are output unprocessed.

B and C TYPE: Dolby noise reduction is an extremely effective method of reducing undesirable background hiss on tapes. This unit incorporates both Dolby B NR and the newer Dolby C NR systems. Dolby C NR is approximately twice as effective as Dolby B NR. When making recordings (of sources except FM. If FM, see MPX ON and OFF.) to be encoded with Dolby NR, set the selector to the desired type of Dolby noise reduction; B or C TYPE MPX OFF. When playing back any tape (even a recording of an FM broadcast) encoded with Dolby B or Dolby C, set the selector to the B TYPE MPX OFF or C TYPE MPX OFF, respectively.

- Dolby and the double D symbol are trademarks of Dolby Laboratories Licensing Corp. Dolby noise reduction system manufactured under license from Dolby Laboratories Licensing Corp.

MPX filter ON and OFF: When recording from FM stations, set the selector to the Dolby NR desired and also set it to the B or C TYPE MPX ON position. However, when not recording FM broadcasts but using Dolby NR, set the selector to the B or C TYPE MPX OFF position.

- FM stations transmit a 19 KHz pilot signal in addition to the broadcast program. Sometimes this pilot signal may leak into the audio output depending on the tuner and broadcast conditions. Since the 19 KHz pilot signal is undesirable, activating the MPX filter will effectively filter out the signal.

⑨ **PLAY TRIM tone control**

PLAY TRIM is a newly developed feature which functions to increase the compatibility between this unit and tapes recorded on another deck. During playback turn this control clockwise to boost high frequencies or turn it counterclockwise to attenuate them. (Refer to "PLAY TRIM" section.)

⑩ **BIAS ADJUST control**

Turning the control counterclockwise decreases the bias and will result in recordings with boosted high frequencies (treble). Too little bias can result in too much or distorted high frequencies. If less distortion is more important than high frequencies, turn the control clockwise to increase the bias signal.

⑪ **AUTO MODE selector**

OFF: For normal playback or recording, set to this position.

FULL REPEAT: In this position (the FULL indicator lights), one side of the cassette can be repeatedly played back 8 times from beginning to end.

0-M REPEAT: With the selector set to this position (the 0-M indicator lights), the section between "000" on the counter and the counter number memorized with the MEMORY button (the MEMO indicator lights) is repeatedly played 8 times (this section must be at least 4 counts long). However, if the MEMORY function is not activated (MEMO indicator is off) but the 0-M REPEAT is selected, any rewinding and fast forwarding of a tape will stop at the display reading of "000".

TIMER PLAY: By using a commercially available audio timer, this function permits timer activated playback.

TIMER REC: By using a commercially available audio timer, this function allows you to carry out unattended recording.

- * Be sure to set this selector to OFF when not using the repeat playback feature or the timer feature. If power is turned on with a cassette loaded in the deck and the selector in the TIMER REC position, the Record mode will be engaged and the prerecorded contents of the tape will be erased.

REMOTE CONTROL TRANSMITTER

⑫ Main operation buttons

◀◀: Press to rapidly rewind (◀◀) the tape.

By pressing this button during recording, the tape will rewind to the beginning of the recording and stop (Rec Return function). If the RESET or the PLAY button was pressed (this does not affect the recording) during recording, the tape will rewind and stop at the point on the tape where the button was pressed.

PLAY: Press this button to begin playback or to engage the Record mode from the Rec/Pause mode. Pressing this button during recording will designate a new beginning point for the Rec Return function (See ◀◀).

▶▶: Press this button to rapidly advance (▶▶) the tape.

REC/PAUSE: Pressing this button engages the Rec/Pause mode, and the REC indicator will light. While in this mode, the PEAK level meters will function, allowing you to monitor and set the recording signal level of the deck. (Refer to the "SETTING RECORDING LEVEL" section.) To initiate recording from the Rec/Pause mode, press the PLAY button. Pressing the REC/PAUSE button during actual recording engages the Rec/Pause mode once again.

STOP: Pressing this button at any time will stop all tape transport functions.

MUTE/SEARCH:

● During Recording (MUTE):

When the MUTE/SEARCH button is pressed at any time during recording, a 4-second blank interval is automatically recorded onto the tape (Auto Rec Mute mode), then the Rec/Pause mode is engaged immediately thereafter. In order to record a blank interval longer than 4 seconds, press the MUTE/SEARCH button and hold it down for the desired length of time. After the button is released, the additional 4-second blank interval will also be recorded, then the Rec/Pause mode is engaged immediately thereafter. When the MUTE function is operating, the REC indicator lights on and off. To resume recording, press the PLAY button.

● During Playback (SEARCH):

By pressing the MUTE/SEARCH and ▶▶ buttons simultaneously, the tape will advance to the beginning of the next selection and begin play.

By pressing the MUTE/SEARCH and ◀◀ buttons simultaneously, the tape will rewind to the beginning of the current selection and begin play.

⑬ EJECT button

Press this button to open the cassette compartment.
The button will not function if the deck is in Play or Record mode.

⑭ PHONES jack

Connect headphones to this jack for monitoring recording or playback.

(See Fig. 2.)

Note: This remote control transmitter is not provided with Europe nor U.K. models. For Europe and U.K. models, the alternative RS-K3 remote control transmitter is available.

① COUNTER RESET and MEMO (MEMORY) keys

These keys have the same functions as the buttons on the deck. The MEMO key on the remote controller is labeled MEMORY on the deck.

② ◀ INTRO ▶ keys

These keys have the same function as the buttons on the deck.

③ ◀◀ SEARCH ▶▶ keys

By pressing ▶▶ key, the tape will advance to the beginning of the next selection and begin play.

By pressing ◀◀ key, the tape will rewind to the beginning of the current selection and begin play.

④ Main operation keys

◀◀ key: Pressing this key will rewind the tape.

PLAY key: Is identical to the PLAY button on the deck.

▶▶ key: Pressing this key will advance the tape.

REC/PAUSE and STOP keys: Are identical to the REC/PAUSE and STOP buttons on the deck.

REC MUTE key: Operates the recording MUTE function of the MUTE/SEARCH button on the deck.

■ BATTERY INSTALLATION (See Fig. 3.)

- ① Press the lid's locking tab down and, at the same time, pull out the battery compartment lid in the direction of the arrow.
- ② Install the batteries (size "AAA", R03) with correct polarities. Follow the diagram in the compartment.
- ③ Position the bottom portion of the compartment lid in place, and push the top portion of the lid in until it clicks into place.

■ REMOTE CONTROL OPERATION RANGE (See Fig. 4.)

The remote control transmitter uses infrared light to control the unit. Therefore, to function properly, there must be a clear, unobstructed path between the transmitter and the sensor on the deck. The normal operating range is about 7 meters (23 feet) and within 30 degrees perpendicular to the front panel.

■ BATTERY REPLACEMENT

When the operating distance of the remote control noticeably decreases, the batteries are exhausted. Immediately replace the batteries with new ones.

- Do not use an old battery together with a new one.
- Install the same type of batteries at the same time. Do not use different kinds of batteries (carbon, alkaline, Ni-Cad, etc.) at the same time even though they are the same shape.
- There are two kinds of batteries in the market: rechargeable and non-rechargeable. Read the caution labels on the battery carefully.

■ BATTERY SAFETY

Incorrect use of the battery can cause leakage or explosion. Proper handling and use of batteries are as follows:

- When the remote control will not be used for an extended period of time, remove the batteries.
- Never disassemble, heat or throw a battery into a fire.
- Do not connect (short circuit) the (+) and (-) poles of a battery with a piece of wire, metal, etc. In case of leakage, thoroughly wipe off all the electrolyte from the battery compartment and install new batteries.

FEATURES

■ DOLBY NOISE REDUCTION

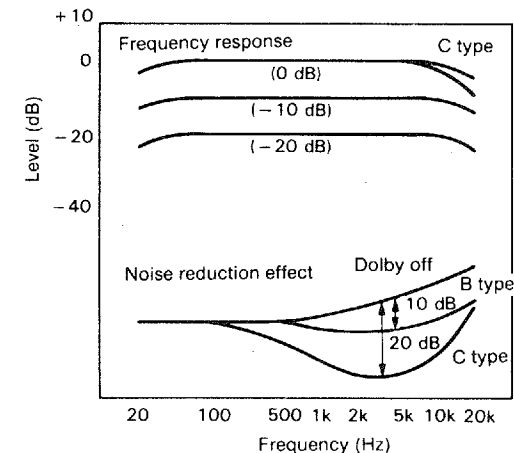

With cassette tapes, the most noticeable form of noise is high frequency hiss. To reduce this hiss noise, the unit is equipped with the newer Dolby C noise reduction system in addition to the older Dolby B NR. Either type of noise reduction may be selected with the DOLBY NR selector. The older Dolby B system is still very handy when playing back that extensive library of Dolby B encoded tapes as well as recording tapes that will be played back on a system which offers only this kind of noise reduction system (some car, portable, and older cassette decks). Dolby B NR has a noise reduction effect of about 10 dB in the high frequency range. The corresponding effect with Dolby C NR is about 20 dB, but this is over the entire range where the human ear is most sensitive to noise (2 kHz to 8 kHz). Dolby C NR also improves the tape's MOL (Maximum Output Level). Dolby C NR has two new circuits: a spectral skewing circuit which is responsible for a reduction in the number of encode/decode errors, and an anti-saturation network which improves the saturation level of the tape, resulting in reduced high frequency loss and improved dynamic range. Also, by expanding the operating frequency range to two octaves more than that of Dolby B NR, overall noise balance is obtained and the system also becomes effective against high frequencies from the power supply transformer.

The graph shows the frequency response and the noise reduction effect of recording and playback with Dolby B NR and Dolby C NR. The noise reduction effect of Dolby C NR is larger — approximately 20 dB.

Dolby noise reduction is a 2 part process that acts both on recording and playback; be sure that the DOLBY NR selector is set to the same position during record and play.

- * Tapes encoded with Dolby NR should be decoded with their respective systems. Nevertheless, a Dolby encoded tape can be played back without decoding (and vice versa) with no harm to the recording.
- * Noise in the source material cannot be reduced with the Dolby NR system.

■ HX PRO DYNAMIC BIAS SERVO SYSTEM

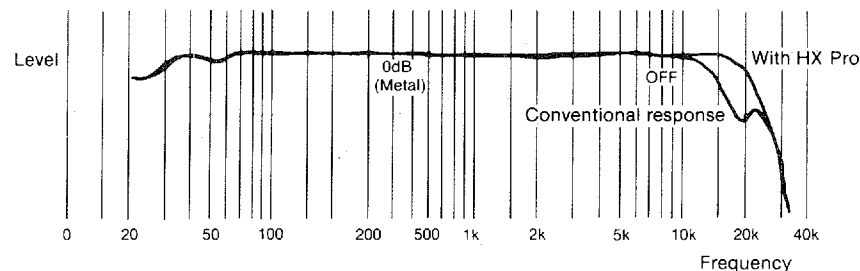

When recording, a bias current according to the tape type used is applied to the recording head as well as the music signal to improve the distortion rate. Furthermore, the extreme high frequency content of a music signal can actually act as bias, adding to the deck's own bias signal to produce over-bias conditions. The result is the deterioration of the high frequency components of the music signal.

To remedy this, the Dolby HX Pro system monitors the total amount of effective bias during recording, and instantaneously compensates for any excess bias by reducing the deck's bias signal level accordingly. The deck operates independently on each channel.

Since HX Pro is not a noise reduction system because it functions only in recording and no decoding is required, a tape recorded with the HX Pro system can be played back on any other cassette deck while retaining the benefits of HX Pro.

Dolby Noise reduction and HX Pro headroom extension are manufactured under license from Dolby Laboratories Licensing Corporation. HX Pro originally developed by Bang & Olufsen.

"DOLBY", the double-D symbol  and "HX PRO" are trademarks of Dolby Laboratories Licensing Corporation.

■ PLAY TRIM

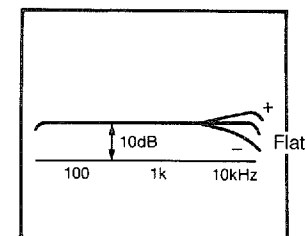

Tapes recorded on one deck can be played back on another. However, slight differences occur between any two decks such as playback frequency response and head azimuth. This occurrence is noticeable when using the Dolby NR system. To solve this problem, this unit incorporates a newly-designed PLAY TRIM control.

With Dolby NR off, the Play Trim circuit makes it possible to control the playback frequency response by approximately ± 3.5 dB at 10 kHz. With Dolby C NR on, the response compensation can extend up to more than ± 10 dB. During playback, turn the PLAY TRIM control to the position which offers the most agreeable sound quality.

When the high-frequency sound is distorted, turn the PLAY TRIM control counterclockwise to attenuate the high frequencies. When the high-frequency sound is not clear, turn the PLAY TRIM control clockwise to boost the high frequencies.

The PLAY TRIM control is similar to the treble tone control of an amplifier. In addition, the PLAY TRIM control functions more effectively with tapes recorded with Dolby NR, because it functions before the Dolby NR decoder circuit.

CONNECTIONS

■ BIAS ADJUSTMENT

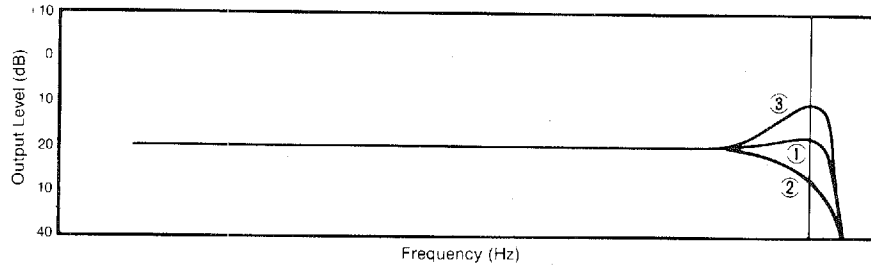

- ① Optimum bias setting
Flat frequency response normal sound quality
- ② Excessive bias (Too little or no high frequency sound)
Turn BIAS ADJUST counterclockwise
- ③ Insufficient bias (Emphasized high frequency sound)
Turn BIAS ADJUST clockwise

This control is for fine adjustment of the recording bias. Normally it is not necessary to adjust this control since the deck's Auto Tape Selector automatically adjusts the recording bias for different tape types. Nevertheless, the deck cannot adjust for the wide range of personal preferences nor for every brand of tape on the market (bias requirements can vary from brand to brand). Should you feel that your recording needs further bias adjusting (absent or distorted high frequencies), refer to the figure and adjust this control to your tastes. Turning the control counterclockwise decreases the bias and will result in recordings with boosted high frequencies (treble). Too little bias can result in too much or distorted high frequencies. If distortion is more important than high frequencies, turn the control clockwise to increase the bias signal.

■ REAR PANEL CONNECTIONS (See Fig. 5.)

Make sure that power to both the deck and your amplifier/receiver are turned off before making any connection. The White plug on the paired connecting cables corresponds to the Left channel and the Red plug corresponds to the Right channel. The LINE OUT/PLAY jacks on the deck should be connected to the Tape PB (Playback/Input) jacks on your amplifier/receiver, and the LINE IN/REC jacks on the deck should be connected to the Rec Out (Rec/Output) jacks on your amplifier/receiver. Make sure that the left and right channel connections are properly made, and that the plugs are inserted firmly. Connect the power cord to an AC wall outlet or to an AC outlet on the rear panel of your amplifier/receiver (if provided).

CASSETTE TAPES

■ CASSETTE TAPES

There are many different types of cassette tapes available, however, they all conform to standard specifications so any brand may be used with the deck.

- * YAMAHA does not recommend the use of 120 minute length cassettes since the extreme thinness of the tape makes them susceptible to mechanical and recording problems.
- Classification of Cassette Tapes by Formulation
Cassette tapes are available in four basic types depending on their formulation, or type of magnetic material and manufacturing process. These four types are commonly known as Normal (Type I/NORM), Chrome (Type II/CrO₂), Ferrichrome (Type III/FeCr), and Metal (Type IV/METAL), and they each require specific tape deck adjustments for optimum performance.

■ AUTO TAPE SELECTOR DETECTION SLOTS (See Fig. 6.)

The deck has a built-in Auto Tape Selector which automatically adjusts for the proper bias, level and equalization according to the tape formulation — all you have to do is load a cassette and the Auto Tape Selector does the rest.

The Auto Tape Selector determines what type of tape is loaded by sensing detector slots in the top of a tape shell. Each tape formulation has its own characteristic hole markings which has been standardized by the tape industry.

- Early model Metal (Type IV/Metal) tape formulation cassette shells do not have the slots for Auto Tape Selector operation. As a result, early model Metal type tapes recorded on another deck will be played back with the deck at the Chrome (Type II/CrO₂) settings. YAMAHA does not recommend recording with this kind of tape on the deck.
- The deck does not have the required setting for Ferrichrome (Type III/FeCr) tape, since this tape formulation is not widely used. Should you use a Ferrichrome tape, it will be recorded and played back at the Normal (Type I/ NORM) settings. And this will result in an unnatural high frequency emphasis. This effect may be compensated for somewhat by adjusting the BIAS ADJUST to the plus (+) direction during recording, or by using the PLAY TRIM tone control and/or the tone controls of your amplifier/receiver during playback.

■ PROTECTING YOUR RECORDINGS (See Fig. 7.)

All cassette tapes are provided with erasure protection holes to prevent accidental erasure of recorded contents. There is a small tab covering the hole on each cassette, and it should be broken off after recording a tape. Without this tab covering the hole, it is impossible to record onto that tape. Thus, you can safely protect a recording for as long as you wish without fear of accidental erasure. Should you wish to use a cassette tape protected in this way for recording, simply covering the hole with adhesive tape will permit erasure and re-recording.

- * When using Chrome (Type II/CrO₂) or Metal (Type IV/METAL) tapes, make sure you do not cover the hole intended for the Auto Tape Selector operation.

■ TAKING UP SLACK IN THE TAPE (See Fig. 8.)

As a precaution against tape entanglement and damage, before inserting cassettes into the deck, remove any slack in the tape. This is accomplished by inserting a pencil, pen or similar object into one of the spools and gently winding it until all the slack is removed. You do not have to wind it too tightly. Be careful not to touch the tape part itself. It is very delicate and touching it may damage the tape and its recorded contents.

■ STORING CASSETTES

After putting a cassette tape back into its case, store in a location away from exposure to direct sunlight, humidity, high temperatures, and magnetic fields (away from television sets, speakers, etc.). High temperatures and humidity will damage the tape itself, while exposure to magnetic fields may cause a loss of recorded material. Avoid touching the tape surface with your fingers, since dirt or finger oil will contaminate the deck's heads.

OPERATION

RECORDING

1. Make sure that the AUTO MODE selector is not set to either TIMER REC or TIMER PLAY. Turn the POWER on.
 2. Load a cassette tape to be recorded. The Auto Tape Selector determines what type of tape is loaded, internally adjusts bias and equalization, and indicates the optimum recording level.
 3. Select the Dolby noise reduction system with the DOLBY NR selector. When recording from an FM station with Dolby NR, set the DOLBY NR selector to B TYPE MPX ON or C TYPE MPX ON, according to the selected Dolby NR system.
 4. Adjust the BIAS ADJUST control if desired. See "BIAS ADJUSTMENT".
 5. Press the REC/PAUSE button to engage the Rec Standby mode, and play a section of the program to be recorded. To prevent tape over-saturation, it is best to play the loudest passage of the source and to set the recording level based on that passage.
 6. Observe the peak reading of the PEAK level meters and adjust the REC LEVEL control so that the highest peak is between 0 dB and +6 dB (Metal tape: +8 dB). Refer to the "SETTING THE RECORDING LEVEL" section. Normally, it is best to adjust the BALANCE control so that the LEFT and RIGHT meter readings are even.
 7. Reset the source to be recorded back to the beginning. Press the PLAY button to begin recording and immediately begin play of the source.
 8. To temporarily stop the recording, press the REC/PAUSE button. To resume recording, press PLAY button.
 9. To stop the recording, press the STOP button.
- When the MUTE/SEARCH button is pressed during recording, a 4-second blank interval is automatically recorded on the tape, then the Rec/Pause mode is engaged (Auto Rec Mute). To resume recording, press PLAY button.
 - When the ◀◀ button is pressed during recording, the tape is automatically rewound to the point at which the recording started (Rec Return).
 - When the counter is RESET to "000" during recording, and the Rec Return function is activated, the tape will be automatically rewound to the "000" point (0-stop).

■ SETTING THE RECORDING LEVEL

Setting the recording level is important for proper recording. The PEAK level meters of this cassette tape deck are equipped with optimum recording level indicators. These indicators do away with the guess work previously associated with setting the recording level. These optimum level indicators appear as lighted segments between the numbers of the signal level scale. They automatically change position according to the tape type loaded (determined by the Auto Tape Selector). Consequently, setting the optimum recording level is an accurate simple operation, enabling the full dynamic range of the tape to be exploited.

1. Load a cassette tape to be recorded.
 2. Select the noise reduction system with DOLBY NR selector. Dot indicator (optimum level indicator) indicates the optimum recording level.
 3. Press the REC/PAUSE button to engage the Rec Standby mode, and play a selection of the program to be recorded.
 4. Watch the PEAK level meters and keep the meter reading no higher than dot indicator (optimum level indicator) by adjusting the REC LEVEL control.
- The  mark indicates the Dolby noise reduction system standard level.

NOTE:

Please check the copyright laws in your country to record from records, compact discs, radio, etc. Recording of copyright material may infringe copyright laws.

PLAYBACK

1. Make sure that the AUTO MODE selector is not set to the TIMER operations, then turn on the POWER switch.
2. Open the cassette compartment by pressing the EJECT button and load a recorded cassette tape.
3. For a tape recorded with a noise reduction system, set the DOLBY NR selector according to the system used in recording.
4. Press the PLAY button to start playback.
5. Set the PLAY TRIM tone control on the deck and the volume and tone controls on the amplifier/receiver to adjust sound quality as desired.
6. To stop playback, press the STOP button.

■ 0-M REPEAT PLAYBACK

With this function, the desired section can be played back repeatedly up to 8 times.

1. Set AUTO MODE selector to 0-M REPEAT position.
 2. Press RESET button at the beginning of the section you want to play repeatedly. The counter reads "000".
 3. Press the MEMORY button at the end of the section. The MEMO indicator lights up, and the tape immediately begins rewinding.
 4. The tape is rewound until the counter has returned to the beginning of the section. The deck then enters the playback mode.
 5. The tape plays until it reaches the specified end of the section, rewinds to the beginning, and plays again. In this way, the same selection can be repeatedly played 8 times. After the 8th time, the deck stops. At this time you can repeat the selection again by pressing the PLAY button.
 6. To erase the memory, press the MEMORY or RESET buttons once again. The MEMO indicator goes out.
- The length between the start and end points of the 0-M repeat section should be more than 4 counts.
 - The 0-M repeat can be carried out between a minus counter reading and "000" (the MEMORY point before the "000" point.)

■ FULL REPEAT PLAYBACK

Set the AUTO MODE selector to FULL REPEAT and start playback. The side being played of the cassette is repeatedly played back 8 times. When the AUTO MODE selector is set to FULL REPEAT, the FULL indicator lights.

■ INTRO SCAN

During playback, press either of the INTRO SCAN buttons. The beginning of each selection is played back for approximately 15 seconds in the selected direction. Press the PLAY button once the desired selection is found. The deck will enter the normal Play mode.

TIMER RECORDING/PLAYBACK (See Fig. 9.)

When using the AUTO MODE selector's TIMER REC or PLAY functions in combination with a commercially available audio timer, it is possible to make recordings and initiate playback at any time automatically.

Timer Recording

1. Make sure that all power cord connections between the timer and amplifier/receiver are properly made. No change in any of the other connections between deck and amplifier/receiver, etc., are necessary.
 2. After turning on the power to each component, select the station on your tuner which you want to record and turn down the volume on your amplifier/receiver. This will have no effect on the recording signal level. Remember to set the proper recording level.
 3. Set the timer to the desired times. It is advisable to set the timer to begin recording slightly before and end slightly after the actual broadcast recording time, so that you leave some room for later editing.
 4. Set the AUTO MODE selector to the TIMER REC position.
 5. The timer will send power to the amplifier/receiver, tuner and deck at the preset time, turning all the components on and initiating the recording mode.
- Be sure to set this selector to OFF when not using the repeat or timer features. If power is accidentally turned on with a cassette loaded in the deck and the selector in the TIMER REC position, the Record mode will be engaged and the recorded contents of the tape will be erased.

NOTE:

If the tape cannot be ejected after timer recording, turn the AUTO MODE selector OFF and the deck's POWER switch ON. The tape can then be ejected.

Timer Playback

1. All connections are the same as for timer recording.
2. Turn on the amplifier/receiver and adjust the Volume and Tone controls.
3. Set the input mode selector of your amplifier/receiver to the Tape mode.
4. Set the timer to the time you wish to start and stop playback.
5. Set the AUTO MODE selector to the TIMER PLAY position.
6. At the preset time, the timer will turn power on to the amplifier/receiver and tape deck and begin playback. It will shut power OFF at the preset time as well, ending playback.

MAINTENANCE

■ CLEANING OF TAPE PATH (See Fig. 10.)

The continued high quality performance of your deck is dependent upon periodic cleaning of the heads, capstan, pinch roller, and all surfaces over which the tape travels. Normal use will cause an accumulation of dirt and dust on the heads, capstans, and pinch rollers. This can lead to poor sound quality, drop outs (intervals with no sound), unsteady tape speed, loss of high frequency response, etc.

Thus, clean the heads and all surfaces over which the tape travels with commercially available cleaning cassette and fluid type cleaners.

■ DEMAGNETIZATION

After 20-30 hours of use, enough residual magnetism will have built up on the heads to cause poor high frequency reproduction. At this time you should use a commercially available head demagnetizer.

- When demagnetizing the heads, be sure to follow the instructions of the head demagnetizer carefully.

SPECIFICATIONS

Track Configuration	4 track, 2 channel stereo
Motor	DC servo motor (main) Flat torque DC motor (reel)
Heads	12-laminated core Amorphous Recording /Playback head Double-gap Ferrite erase head
Rapid Transport (F.Fwd/Rew)	90 sec. (C-60)
Wow and Flutter WRMS	0.05%
W.Peak	±0.08%
Signal-to-Noise Ratio (Dolby NR off)	better than 60 dB
(Dolby B NR on)	better than 68 dB
(Dolby C NR on)	better than 76 dB
Frequency Response Normal tape (-20 dB)	20 — 17,000 Hz ±3 dB
CrO ₂ tape (-20 dB)	20 — 19,000 Hz ±3 dB
Metal tape (-20 dB)	20 — 20,000 Hz ±3 dB
Harmonic Distortion Normal tape	less than 1.0%
Chrome tape	less than 1.0%
Metal tape	less than 1.0%
Input Sensitivity/Impedance Line	50 mV/50 k-ohms
Output Level Line	360 mV/1.2k-ohm
Phones	0.1 mW/8 ohms
Channel Separation (3150 Hz)	40 dB
Cross Talk (125 Hz)	55 dB

GENERAL

Power Supplies

U.S.A. and Canada model	120V, 60 Hz
Europe model	220V, 50 Hz
U.K. and Australia model	240V, 50 Hz
Other model	110, 120, 220, 240 V, 50/60 Hz

Power Consumption

17 W

Dimensions (W x H x D)

435 x 117 x 273 mm
(17-1/8" x 4-5/8" x 10-3/4")

Weight

4.6 kg (10 lbs. 6 oz.)

* Specifications subject to change without notice.

TROUBLESHOOTING

If your cassette deck fails to operate normally, check the following table. It lists common operating errors and simple measures which you can take to correct the problem. If it cannot be corrected, or the symptom is not listed, disconnect the deck's power cord and contact your local YAMAHA dealer or service center for help.

Fault	Cause	Cure
Tape doesn't move in recording or playback.	<ul style="list-style-type: none"> ● Power plug not properly plugged in. ● End of tape. ● Cassette shell is warped or damaged. 	<ul style="list-style-type: none"> ● Reinsert plug properly. ● Rewind tape or flip it over. ● Do not play damaged tapes.
REC/PAUSE button fails to function.	<ul style="list-style-type: none"> ● No cassette tape loaded. ● Recording protection tab is broken off. 	<ul style="list-style-type: none"> ● Load a cassette tape. ● Change to different tape, or cover the hole remaining after removal of tab with cellophane tape.
Sounds become faint and sometimes inaudible.	<ul style="list-style-type: none"> ● Head is dirty. ● Head is magnetized. ● Tape is damaged or of poor quality. 	<ul style="list-style-type: none"> ● Clean head. ● Demagnetize head using head demagnetizer. ● Change to a different tape.
Recorded sound is distorted.	<ul style="list-style-type: none"> ● Tape is bad (stretched or deformed, etc.). ● Cassette shell is warped. 	<ul style="list-style-type: none"> ● Replace with a fresh tape. ● A warped cassette shell cannot be fixed. Replace with another tape and test.
Recorded sounds are distorted.	<ul style="list-style-type: none"> ● Recording level is too high. 	<ul style="list-style-type: none"> ● Check input level with signal level meter and use lower rec level when recording.
Tape is playing back, but no sound is heard.	<ul style="list-style-type: none"> ● Faulty connection between deck and stereo amplifier/receiver. 	<ul style="list-style-type: none"> ● Check and secure connections.
Excessive noise.	<ul style="list-style-type: none"> ● Head is dirty. ● Head is magnetized. ● Worn out or poor quality tape. ● Connection(s) improperly made. ● Affected by external electrical noise. 	<ul style="list-style-type: none"> ● Clean head. ● Demagnetize head with head demagnetizer. ● Change to better tape. ● Check input and output connections and reinsert properly. ● Move away from electrical appliances (TV, fluorescent light, electric blanket, etc.).
Excessive wow (wavering of the sound).	<ul style="list-style-type: none"> ● Dirty capstan, pinch roller, etc., or poor tape. ● Tape is wound unevenly. 	<ul style="list-style-type: none"> ● Clean capstan, pinch roller, or change to better tape. ● Rewind tape.
Tape stops in the middle of recording or playback.	<ul style="list-style-type: none"> ● Slack tape, or tape spillage wound around capstan. 	<ul style="list-style-type: none"> ● Insert pencil in hole in cassette shell and turn to take up slack.

Fault	Cause	Cure
Fails to record.	<ul style="list-style-type: none"> ● REC LEVEL control too low. ● Protective tabs broken off. 	<ul style="list-style-type: none"> ● Adjust REC LEVEL control. ● Change tape or cover protective hole with cellophane tape.
Mute Search does not operate.	<ul style="list-style-type: none"> ● Recorded section is too short. ● Recorded section has low-level portions. ● Conversation, etc. has been recorded. 	<ul style="list-style-type: none"> ● Blank sections must be at least 4 seconds long.
High frequencies in the playback sound are emphasized and unpleasant to listen to, and noise level (hiss) is also high.	<ul style="list-style-type: none"> ● Dolby-recorded tape is played back in OFF position. 	<ul style="list-style-type: none"> ● Playback in appropriate Dolby NR position.
Playback sound is muffled and high frequencies are inaudible.	<ul style="list-style-type: none"> ● Normally-recorded tape is played back in Dolby NR ON position. ● Heads are dirty. ● Heads are magnetized. 	<ul style="list-style-type: none"> ● Playback in OFF position. ● Clean heads and carry out demagnetization with head demagnetizer.
When playing back tapes recorded on other decks, meter deflections are greater (smaller) than when recording.	<ul style="list-style-type: none"> ● Basic levels are different for different cassette decks. 	<ul style="list-style-type: none"> ● This is not a fault.
Recordings cannot be made with TIMER REC (deck only plays back).	<ul style="list-style-type: none"> ● Protective accidental erasure tabs on cassette have been broken off. 	<ul style="list-style-type: none"> ● Replace cassette tape, or cover tab holes with tape, etc.

YAMAHA

YAMAHA ELECTRONICS CORPORATION, USA 6722 ORANGETHORPE AVE., BUENA PARK, CALIF. 90620, U.S.A.
YAMAHA CANADA MUSIC LTD. 135 MILNER AVE., SCARBOROUGH, ONTARIO M1S 3R1, CANADA
YAMAHA ELECTRONIK EUROPA G.m.b.H. 2084 RELINGEN, BEI HAMBURG, SIEMENSSTR 22/34, F.R. OF GERMANY
YAMAHA ELECTRONIQUE FRANCE S.A. 17 RUE DES CAMPANULES, LOGNES 77321 MARNE LA VALLEE CEDEX 2 FRANCE
YAMAHA ELECTRONICS (UK) LTD. YAMAHA HOUSE, 200 RICKMANSWORTH ROAD WATFORD, HERTS WD1 7JS, ENGLAND
YAMAHA SCANDINAVIA A.B. J A WETTERGRENS GATA 1, BOX 30053, 400 43 VASTRA FRÖLUNDA, SWEDEN
YAMAHA MUSIC AUSTRALIA PTY, LTD. 17-33 MARKET ST., SOUTH MELBOURNE, 3205 VIC., AUSTRALIA

YAMAHA CORPORATION
10-1 NAKAZAWA-CHO, HAMAMATSU, JAPAN
VI73680-0 BWgW, BR  Printed in Japan